

NC Specifications / FANUC Series

	Item	Specification
Controlled axis	Controlled Axes	2 axis(X,Z)
	Max. Simultaneously Controlled Axes	Positioning(G00) / Linear Interpolation(G01) Circular Interpolation(G02, G03)
	Least Input Increment	0.001mm
Spindle Function	Spindle Speed Control	S5 (5 digit)
	Spindle Speed Override	50~120%
	Spindle Orientation	M19
Feed Function	Feedrate Override (10% increase)	0~200%
	Dwell	G04
	Reference Position Return	G27, G28
	Manual Pulse Generator	0.001/0.01/0.1mm
	Dry Run	F0(Fine Feed), 25/50/100%
Tool Functions	Rapid Traverse Override	F0(Fine Feed), 25/50/100%
	Tool Number Command	T2(2 Digit)
	Tool nose radius compensation	G40 ~ G42
	Tool offset pair	128EA
Programming Function	Tool geometry/wear offset	GEOMETRY & WEAR DATA
	Canned Cycle	G70~G72, G74~G76
	Decimal Point Input	Able to input up to decimal point
	Sub Program	4Phase
	Work Coordinate System	G52~G59
Tape Functions	Max Program Dimension	±99999.999mm
	M Function	M3(3 Digit)
	Input Code	ISO/EIA Auto Recognition
	I/O Interface	RS232C
	rogram Storage Space	1280M(512kb)
Other Functions	Number of stored programs	400EA
	Display Unit / MDI	10.4" color LCD / Soft input type MDI
	Synchronized Tapping	Rigid Tapping Function
	Background Tapping	Program saving/editing during automatic operation
	Backlash Compensation	Pitch Error Offset Compensation for Each Axis
	Search Function	Sequence / program number search
	Safety Function	Emergency stop / overtravel
	Program Test Function	Machine Lock / Single Block
	Control Function	Memory / MDI / Manual
	Mirror Image	
	Run hour and parts count display	
Custom Macro	#100 ~ #199, #500 ~ #999	

SMEC

SL 5500 series

HORIZONTAL TURNING CENTER



SMEC
SMEC CO.,LTD.

SMEC Co., Ltd.

157-10, Goldenroot-ro, Juchon-myeon, Gimhae-si, Gyeongsangnam-do, Korea

Tel +82 55 340 4800 Fax +82 55 340 4740

<http://www.esmec.com>



SMEC
SMEC CO.,LTD.

- 1988 - Started as Samsung Heavy Industries Machine Tools Business
- 1989 - Horizontal and vertical machining center technology partnership with OKK Japan
- 1991 - Turning center and vertical machining center technology partnership with Mori Seiki
- 1996 - 5-sided processing center technology partnership with Toshiba
- 1999 - Spun out from Samsung Aerospace Industries and established SMEC Co., Ltd

SMEC

Company

Engineering

Machine Tools

Samsung

SL 5500/5500M/5500L/5500LM SL 5500C/5500CM/5500CL/5500CLM

Strongest in class with superb structural design
Simultaneous heavy duty and precision turning

- 45 degree torque tube type bed to support heavy duty turning
- Significantly reduced non-cutting time and efficient turning
- Low-center of gravity reducing vibration, thermal deformation and improving rigidity

High Accuracy, High Rigidity Spindle

Pin Tube Rib Design for Minimal Axis Heat Transfer

Radiator fan-like pin tube rib design dissipates heat generated by axis movements, maintaining minimal thermal expansion.

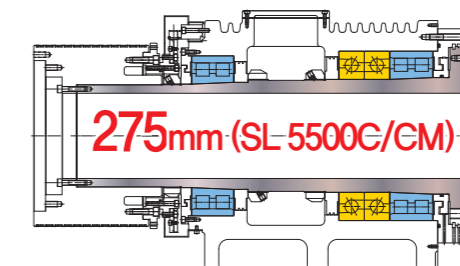
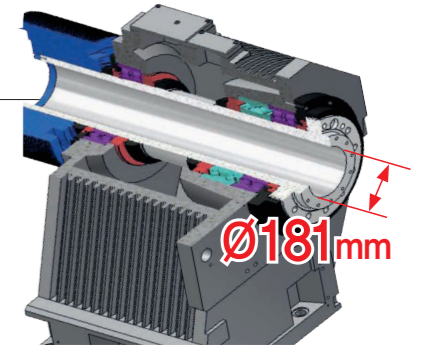

Output Converting Transmission

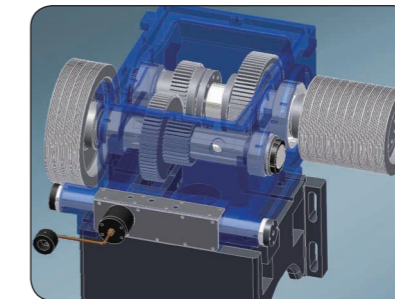

Equipped as standard feature, high Output Converting Transmission provides heavy-duty machining.

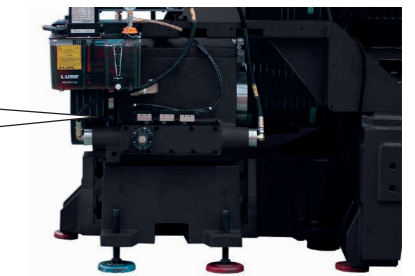

Spindle Power & Torque Diagram

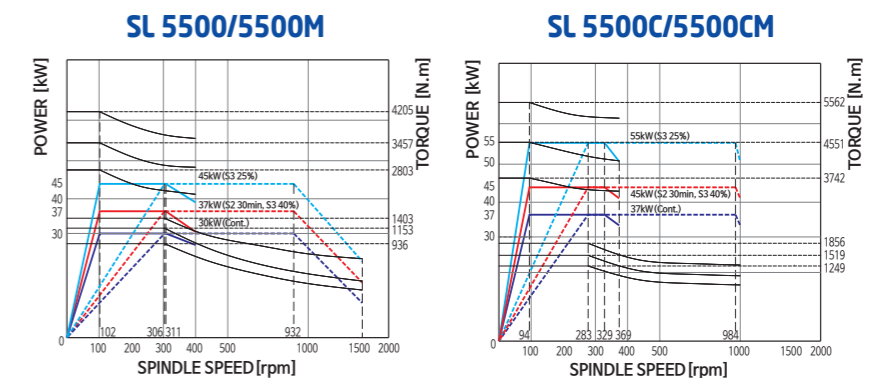

An innovative high precision, heavy duty CNC Lathe,
integrated with all of SMEC's advanced technology
- **SL 5500 series**

Spindle speed
1,500 rpm (SL 5500/M/L/LM)
1,000 rpm (SL 5500C/CM/CL/CLM)

Max. machining length[MC(BMT 75/85)]
1,097 [(1,079/1,045)] mm (SL 5500/M)
2,197 [(2,179/2,145)] mm (SL 5500L/LM)
1,097 [(1,079/1,045)] mm (SL 5500C/CM)
2,197 [(2,179/2,145)] mm (SL 5500CL/CLM)

Spindle motor(30min/cont.)
45/30 kW (SL 5500/M/L/LM)
55/37 kW (SL 5500C/CM/CL/CLM)

Feed motor(X/Z)
7/6 kW

Rapid traverse(X/Z)
20/20 m/min

Max. machining dia.[BMT 85]
Φ690 [Φ650] mm



Highly Reliable and Rigid Structural Design

- One piece Meehanite casting with heavily ribbed torque tube design
- Rigid bed supports for powerful cutting
- Excellent vibration dampening and thermal displacement design

SL 5500 (High Speed Servo Index Hydraulic Turret)

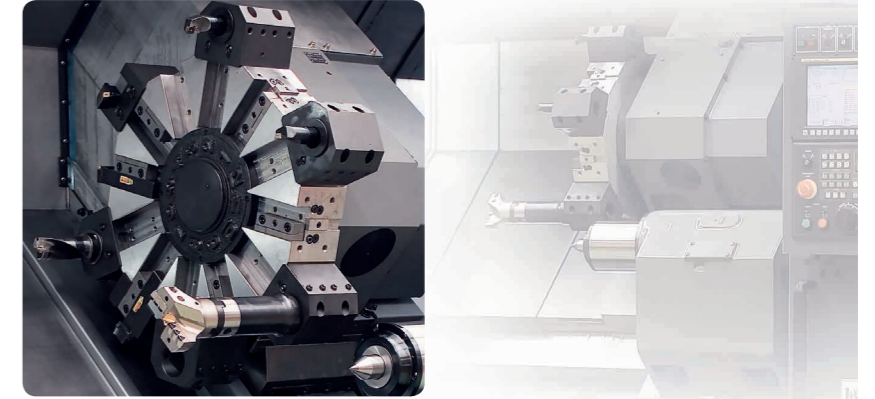

Indexing Time
0.25 sec(60 Hz)

Number of tool positions
12 stations

High Speed, Heavy Duty Servo Turret

Driven by a high torque servo motor, the 12-station heavy -duty turret can accept tools on both left and right side of each station. Turret indexing (repeatability ± 0.01) is non-stop, bi-directional with a fast 0.25 second next station index time. Large diameter (Ø320) precision Curvic coupling with 159,300N clamping force enables precision as well as heavy-duty cutting.

SL 5500M (BMT High Speed Turret)

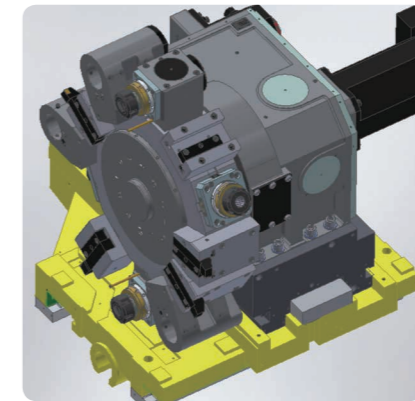

Turret Torque Diagram(BMT75)

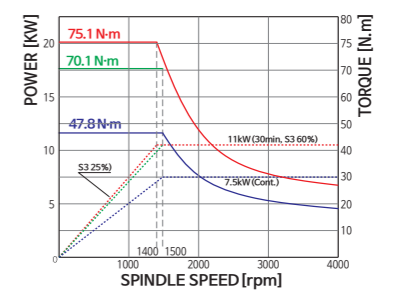

Indexing Time
0.25 sec(60 Hz)

Number of tool positions
12 stations

Milling Spindle Speed
4,000 rpm(3,000 with BMT85/opt.)

Tool Holder
BMT 75(85 Opt.)

BMT Milling Turret (M Type)

SL 5500M is equipped with standard 12-station BMT turret capable of accepting rotary tools at any station, providing flexible machining thru various machining operations in just one set-up. Each BMT holder is securely tightened by 4~6 screws, allowing the turret to perform heavy-duty cutting, milling and drilling operations. Turret indexing is non-stop, bi-directional with a fast 0.25 second next station index time.



Centralized Operation Panel

The centralized operation panel with its 10.4 inch color TFT LCD monitor is able to swivel 90 degrees, providing operators with easy access to the control panel while working on the machine.

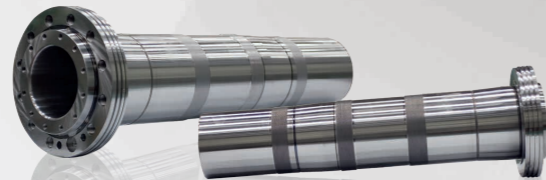

Rigid 45 degree Slant Bed

45 degree slant torque tube design bed and wide guide slide way ensure long term rigidity and machining accuracy. Also, the Slant Type structure allows for easier access to the workpiece and superb chip discharge.

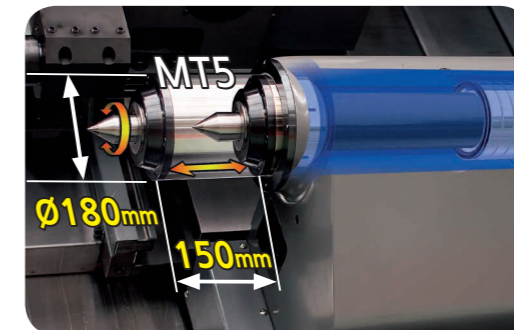
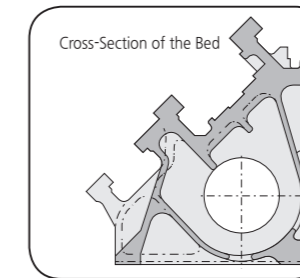

Programmable Tailstock (Carriage direct-coupled) [Std.]

The programmable tailstock body mounted is on wide guide ways to ensure rigid work piece support.

Fast Indexing and Heavy-Duty Turret Design

All axes ballscrews are pre tensioned, heat treated and fixed by double anchors on both ends, providing ultimate rigidity and minimal thermal growth. Both ends are supported by P4 class high precision angular bearing and run by big Dia. high precision ballscrews.

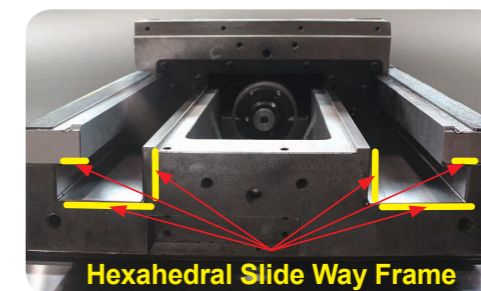
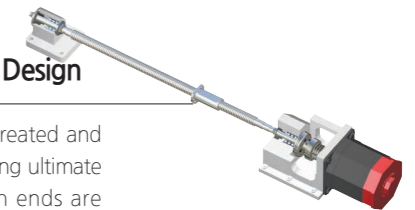

Hexahedral Slide Way Frame (X-axis)

Wide integral way is machined from the casting, induction hardened and precision ground to ensure long-term rigidity, machining accuracy and heavy-duty machining.

High Precision

Surface Roughness

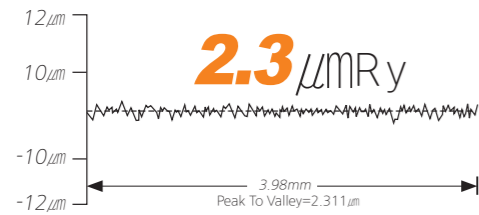

Model : SL 5500

Roundness

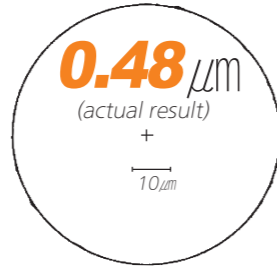

Cutting condition	
Tool	Diamond tool <nose radius 0.5mm>
Material	AL150<Aluminum>
Cutting speed	230 m/min
Feedrate	0.05 mm/rev
Depth of cut	0.1 mm
Outer diameter	200 mm
Filter	1-50

Processing Speed

Turning Performance (material:SM45C) SL 5500

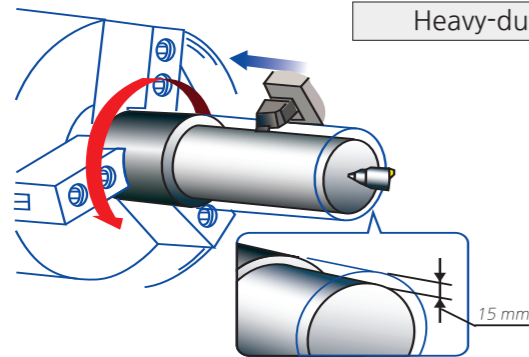

Spindle speed
367 rpm
Cutting speed
150 m/min
Depth of cut
15 mm <Spindle Load 65%>
Feedrate
0.4 mm/rev

Standard Accessories

Optional Accessories



Automatic Lubricator

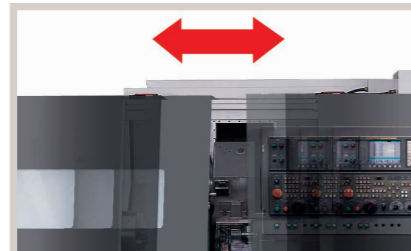

Auto Door



Tool Presetter

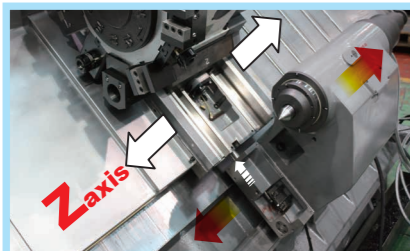

Programmable Tailstock



Chip Conveyor

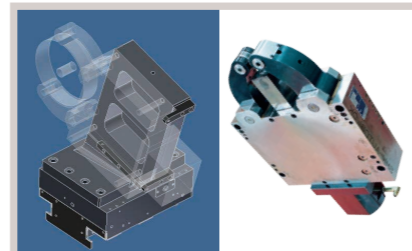

Steady Rest & Preparation

Machine Dimensions

Unit : mm

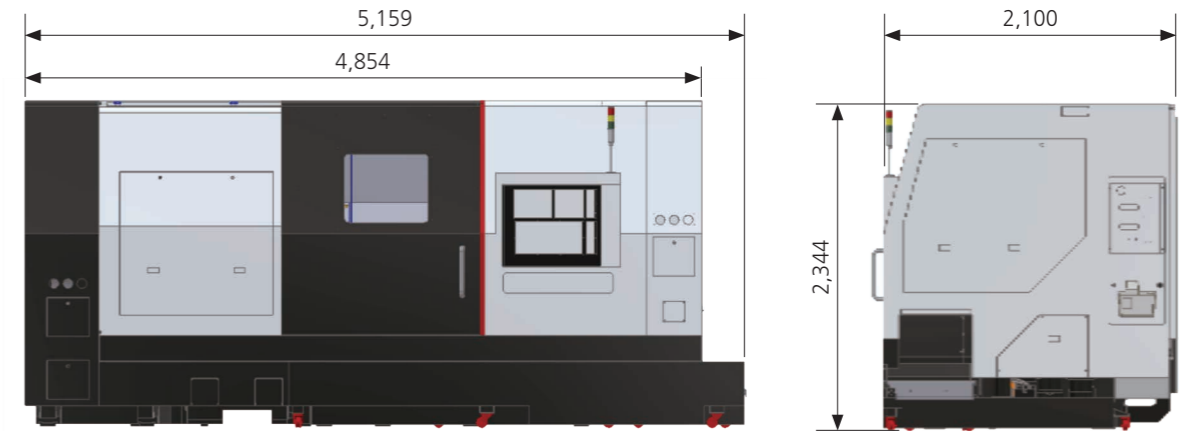

Tooling System

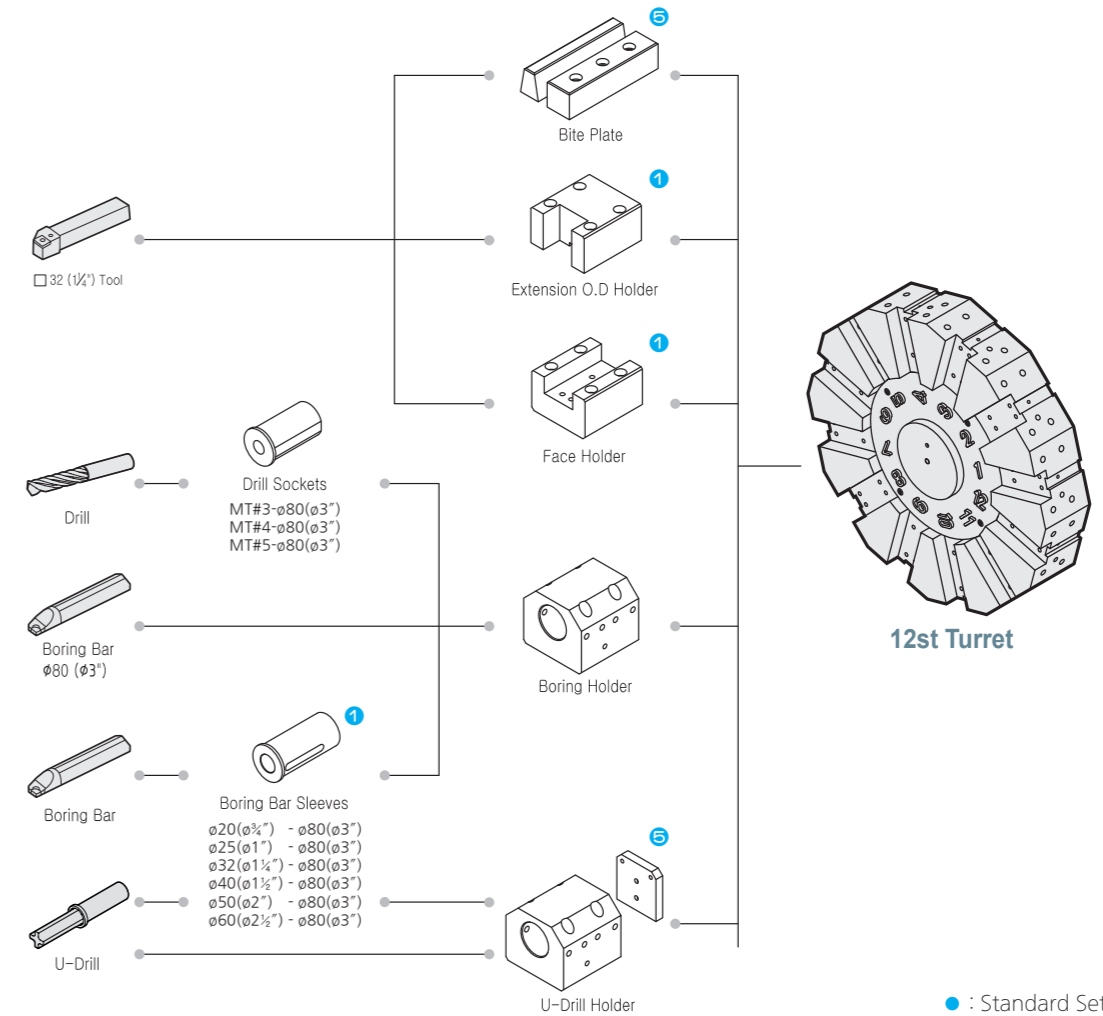

Tooling System

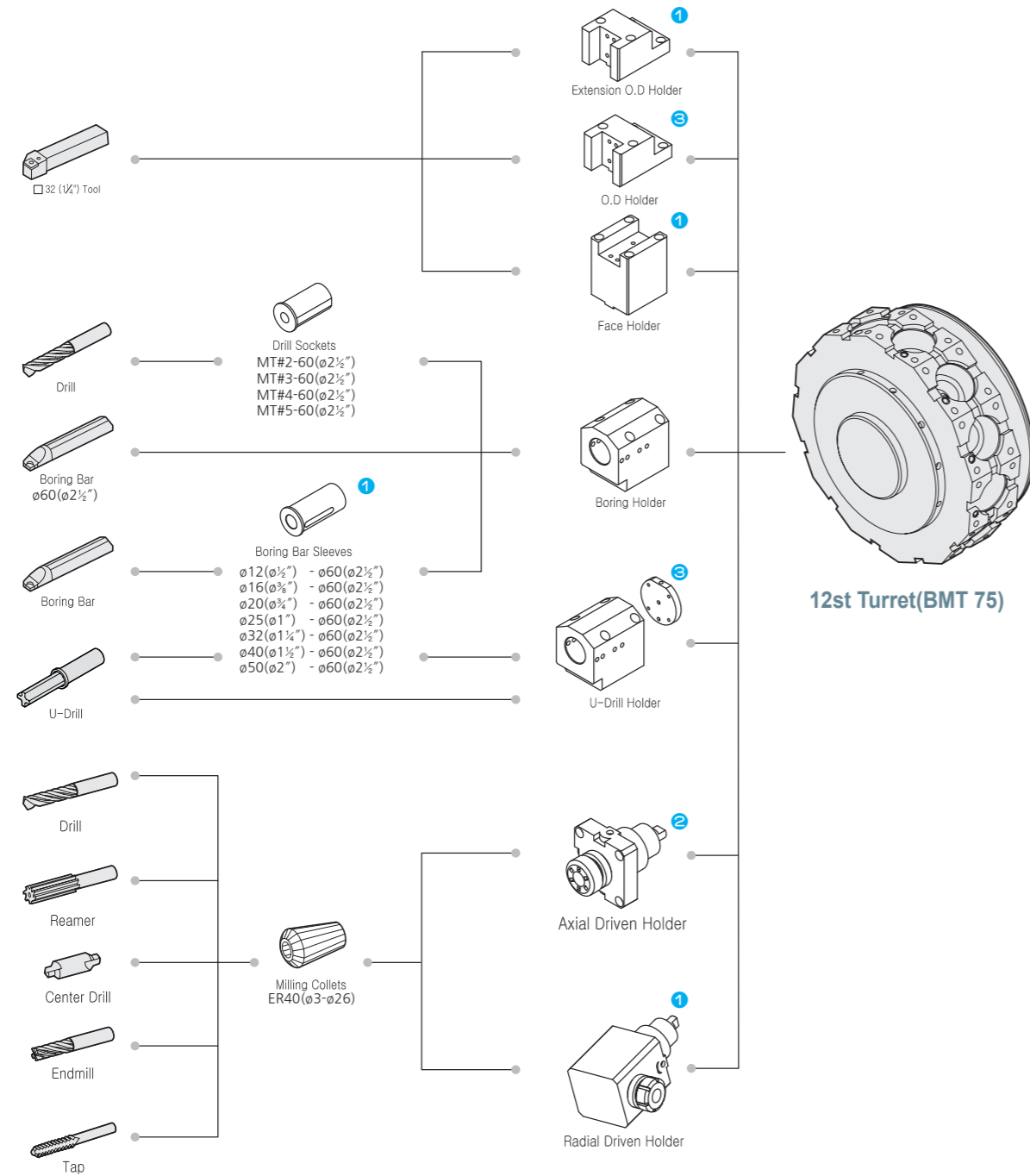

● : Standard Set Numbers

Tooling System

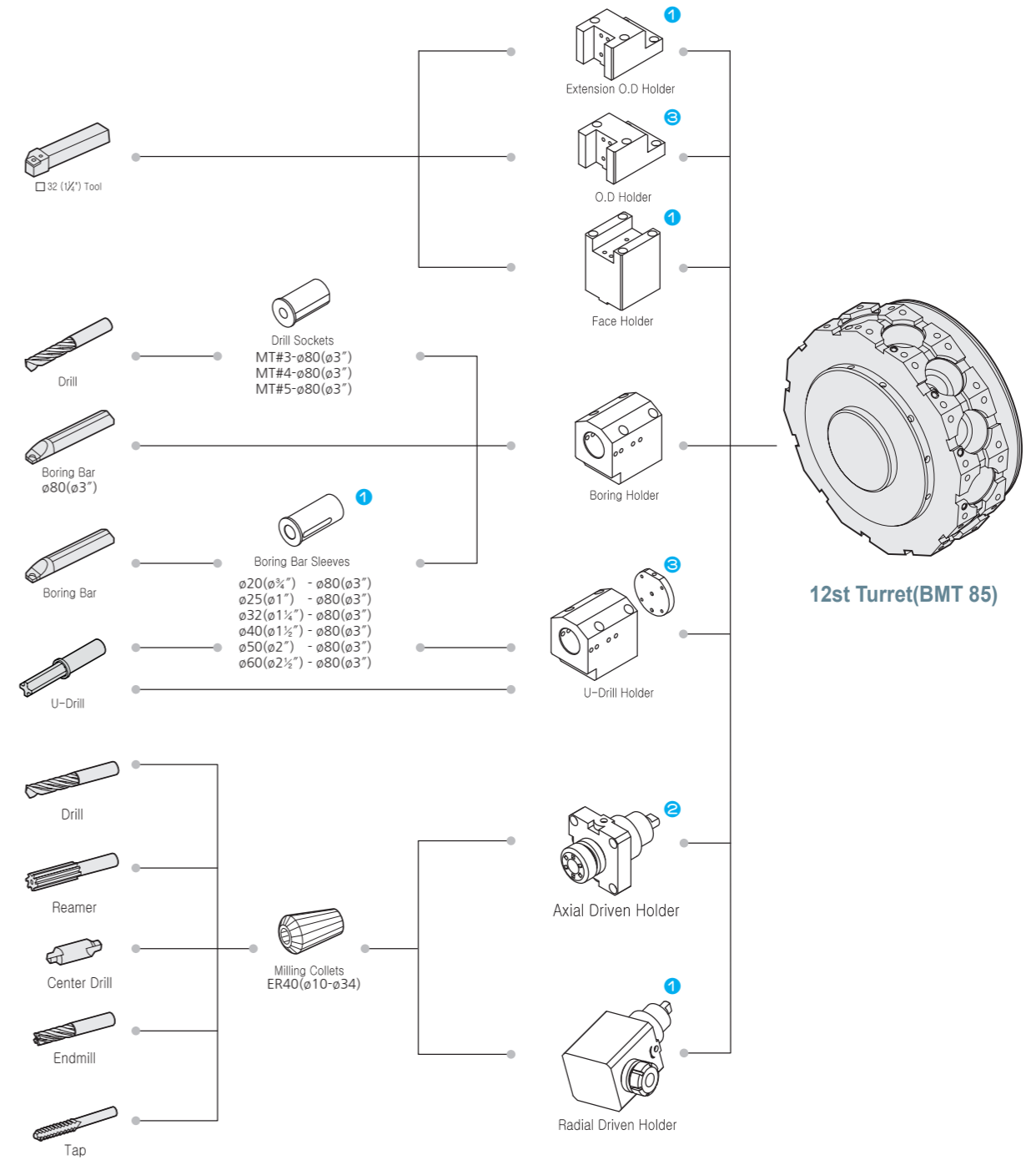

● : Standard Set Numbers

Work Range

Unit : mm

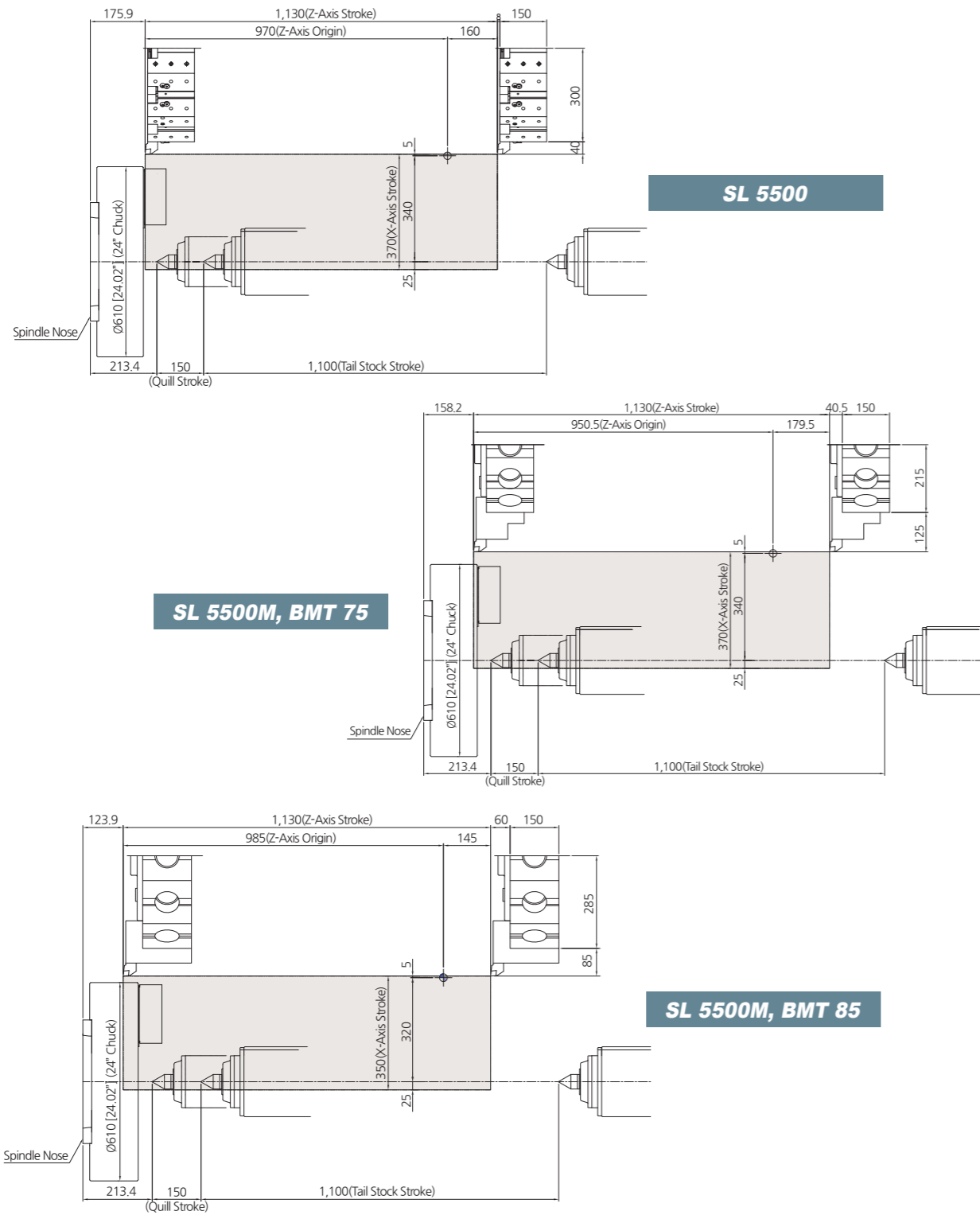

Turret Interference

Unit : mm

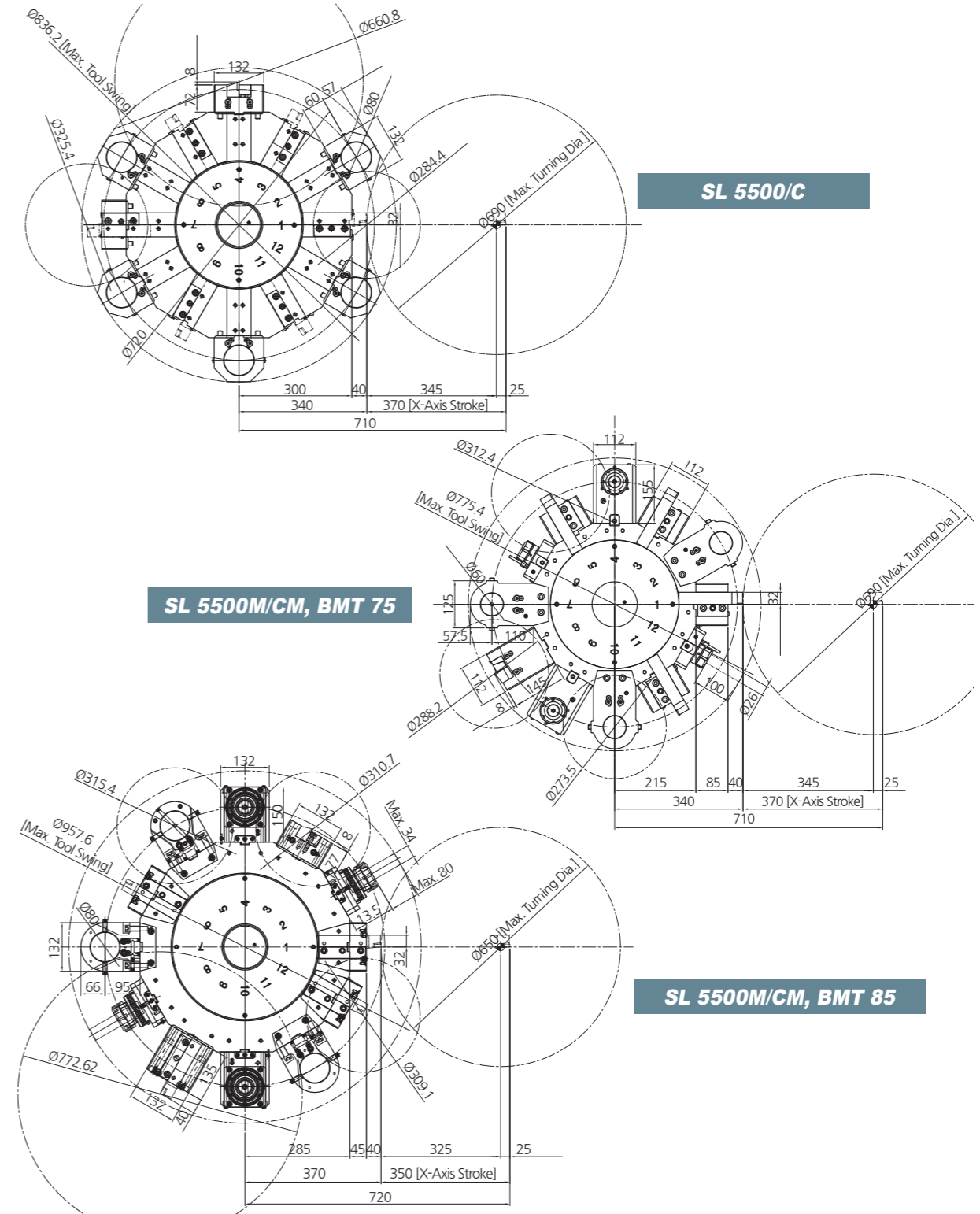

Major Specifications

DESCRIPTION		SL 5500	SL 5500M	SL 5500L	SL 5500LM
Capacity	Swing over the bed mm	900	900	900	900
	Swing over the cross slide mm	800	800	800	800
	Max. turning diameter mm	690	690 [650]	690	690 [650]
	Max. Milling diameter mm	-	793	-	793
	Max. turning length mm	1,097	1,079	2,197	2,179
	Draw tube ID mm	165.5	165.5	165.5	165.5
	Travels	X axis travel mm	370	370 [350]	370
Z axis travel mm		1,130	1,130	2,230	2,230
Main Spindle	Max. spindle speed rpm	1,500[1,200]	1,500[1,200]	1,500[1,200]	1,500[1,200]
	Chuck size inch	21[24]	21[24]	21[24]	21[24]
	Spindle nose ASA	A2-15	A2-15	A2-15	A2-15
	Spindle bore diameter mm	181	181	181	181
	Min. spindle indexing angle(C-Axis) deg	-	0.001	-	0.001
Turret	Number of tool stations [option] ea	12	12(BMT75) [BMT85]	12	12(BMT75) [BMT85]
	Shank size for square tool mm	32	32	32	32
	Shank diameter for boring bar mm	80	60 [80]	80	60 [80]
	Indexing time sec	0.25	0.25	0.25	0.25
	Rotary tool spindle speed rpm	-	4,000 [3,000]	-	4,000 [3,000]
Feed Rate	Rapid traverse (X/Z) m/min	20/20	20/20	20/20	20/20
Motor	X axis feed motor kW	7	7	7	7
	Z axis feed motor kW	6	6	6	6
	Spindle drive motor(cont./30min) kW	45/30 [55/37]	[55/37]	[55/37]	[55/37]
	Rotary tool spindle motor(cont./30min) kW	-	11/7.5	-	11/7.5
Tailstock	Tailstock quill stroke mm	150	150	150	150
	Quill diameter mm	160	160	160	160
	Quill bore taper MT	MT5(BUILT-IN)	MT5(BUILT-IN)	MT5(BUILT-IN)	MT5(BUILT-IN)
ELECTRIC POWER SUPPLY kVA/V	62/220	62/220	62/220	62/220	
REQUIRED FLOOR SPACE(with chip conveyor)(LxWxH) mm	5,159(6,040)×2,173×2,344		6,259(7,140)×2,173×2,344		
MACHINE WEIGHT kg	15,000	15,500	15,900	16,400	
CONTROLLER	Fanuc Series				

※Figures in inches are converted from metric measurements.

※[] : Option

Major Specifications

DESCRIPTION		SL 5500C	SL 5500CM	SL 5500CL	SL 5500CLM	
Capacity	Swing over the bed mm	900	900	900	900	
	Swing over the cross slide mm	800	800	800	800	
	Max. turning diameter mm	690	690 [650]	690	690 [650]	
	Max. Milling diameter mm	704	-	704	-	
	Max. turning length mm	1,097	1,079	2,197	2,179	
	Draw tube ID mm	231	231	231	231	
Travels	X axis travel mm	370	370 [350]	370	370 [350]	
	Z axis travel mm	1,130	1,130	2,230	2,230	
Main Spindle	Max. spindle speed rpm	1,000	1,000	1,000	1,000	
	Chuck size inch	-	-	-	-	
	Spindle nose ASA	A2-20	A2-20	A2-20	A2-20	
	Spindle bore diameter mm	275	275	275	275	
Turret	Min. spindle indexing angle(C-Axis) deg	-	0.001	-	0.001	
	Number of tool stations [option] ea	12	12(BMT75) [BMT85]	12	12(BMT75) [BMT85]	
	Shank size for square tool mm	32	32	32	32	
	Shank diameter for boring bar mm	80	60 [80]	80	60 [80]	
	Indexing time sec	0.25	0.25	0.25	0.25	
Feed Rate	Rotary tool spindle speed rpm	-	4,000 [3,000]	-	4,000 [3,000]	
	Rapid traverse (X/Z) m/min	20/20	20/20	20/20	20/20	
	Motor	X axis feed motor kW	7	7	7	7
		Z axis feed motor kW	6	6	6	6
Spindle drive motor(cont./30min) kW		55/37	55/37	55/37	55/37	
Rotary tool spindle motor(cont./30min) kW		-	11/7.5	-	11/7.5	
Tailstock	Tailstock quill stroke mm	150	150	150	150	
	Quill diameter mm	160	160	160	160	
	Quill bore taper MT	MT5(BUILT-IN)	MT5(BUILT-IN)	MT5(BUILT-IN)	MT5(BUILT-IN)	
ELECTRIC POWER SUPPLY kVA/V	62/220	62/220	62/220	62/220		
REQUIRED FLOOR SPACE(with chip conveyor)(LxWxH) mm	5,159(6,040)×2,173×2,344		6,259(7,140)×2,173×2,344			
MACHINE WEIGHT kg	15,500	16,000	16,400	16,900		
CONTROLLER	Fanuc Series					

※Figures in inches are converted from metric measurements.

※[] : Option

Standard Accessories

- Coolant System (4.5 bar-60Hz)
- Work light (Led lamp)
- Splash guard with side coolant tank
- Tool box
- 21" Hyd. Hollow chuck(SL 5500/M)
- Soft Jaw (3set)
- Hard Jaw(1set)
- Leveling unit
- Main spindle orientation
- Chuck clamp foot switch
- Chuck clamp confirmation
- Chuck pressure switch
- Manual/Part list
- Safety precaution name plate
- Door interlock
- Patrol Lamp

Optional Accessories

- Chuck(SL 5500C/CM)
- Side chip conveyor
- Chip bucket
- Special chuck
- Dual pressure chucking
- Air gun
- Air blower
- Oil skimmer
- Chuck coolant
- Coolant gun
- Steady Rest(ASR 4.0/5.1)